



**AERO CLUB D'ITALIA**

		Form A
Pilot ID	AeC Italia Glider INTERMEDIA Imposto Conosciuto	
		Flight #

No	Symbol	Cat. No.	K	Total K	Grade	Pos	Remarks	Item	K	Grade
1		1.1.2.3	7	7	.			Pos.	10	
								Harm.	15	
2		8.4.3.1	15	15	.			Fig K	Total K	
								110	135	
3		5.2.1.1	17	17	.			<b>Penalties</b>		
								Too Low		
								Too High		
								Interruptions		
								Insertions		
								Trg Violation		
								Wing Rocks		
								Disqual Fig		
Other(note...)										
5		2.2.1.1	4	4	.			<b>Final Freestyle</b>		
								Duration	Min	Sec
6		1.1.1.1 9.1.3.4	2 12	14	.			Signature		
								Name		
								Number		
7		5.2.1.1	17	17	.					
8		7.4.1.1	10	10	.					
9		1.1.2.1	7	7	.					

LIMITATO  
A/C  
Pilot

		Form B
Pilot ID	AeC Italia Glider INTERMEDIA Imposto Conosciuto	Flight #

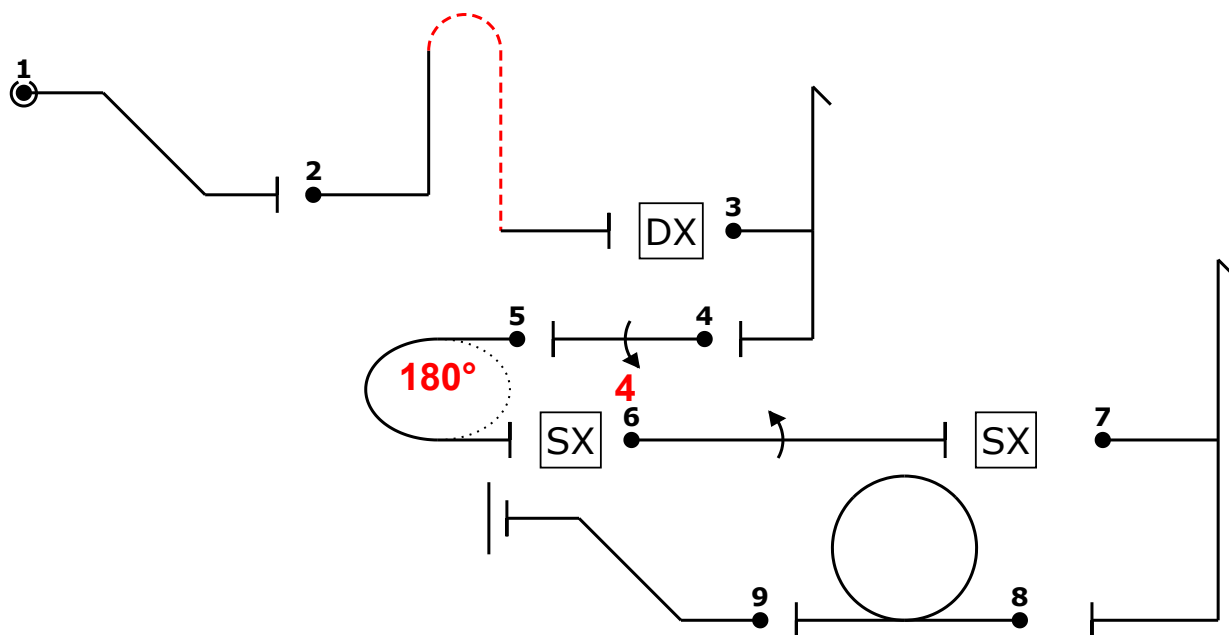
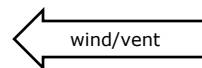

Glider			
Fig	Aresti	K	
1	1.1.2.3	7	7
2	8.4.3.1	15	15
3	5.2.1.1	17	17
4	1.1.1.1 9.4.3.4	2 17	19
5	2.2.1.1	4	4
6	1.1.1.1 9.1.3.4	2 12	14
7	5.2.1.1	17	17
8	7.4.1.1	10	10
9	1.1.2.1	7	7
<b>Total K = 110</b>			

\_\_\_\_\_  
 ..... Pilot  
**LIMITATO**  
 ..... A/C



		Form C
Pilot ID	AeC Italia Glider INTERMEDIA Imposto Conosciuto	Flight #

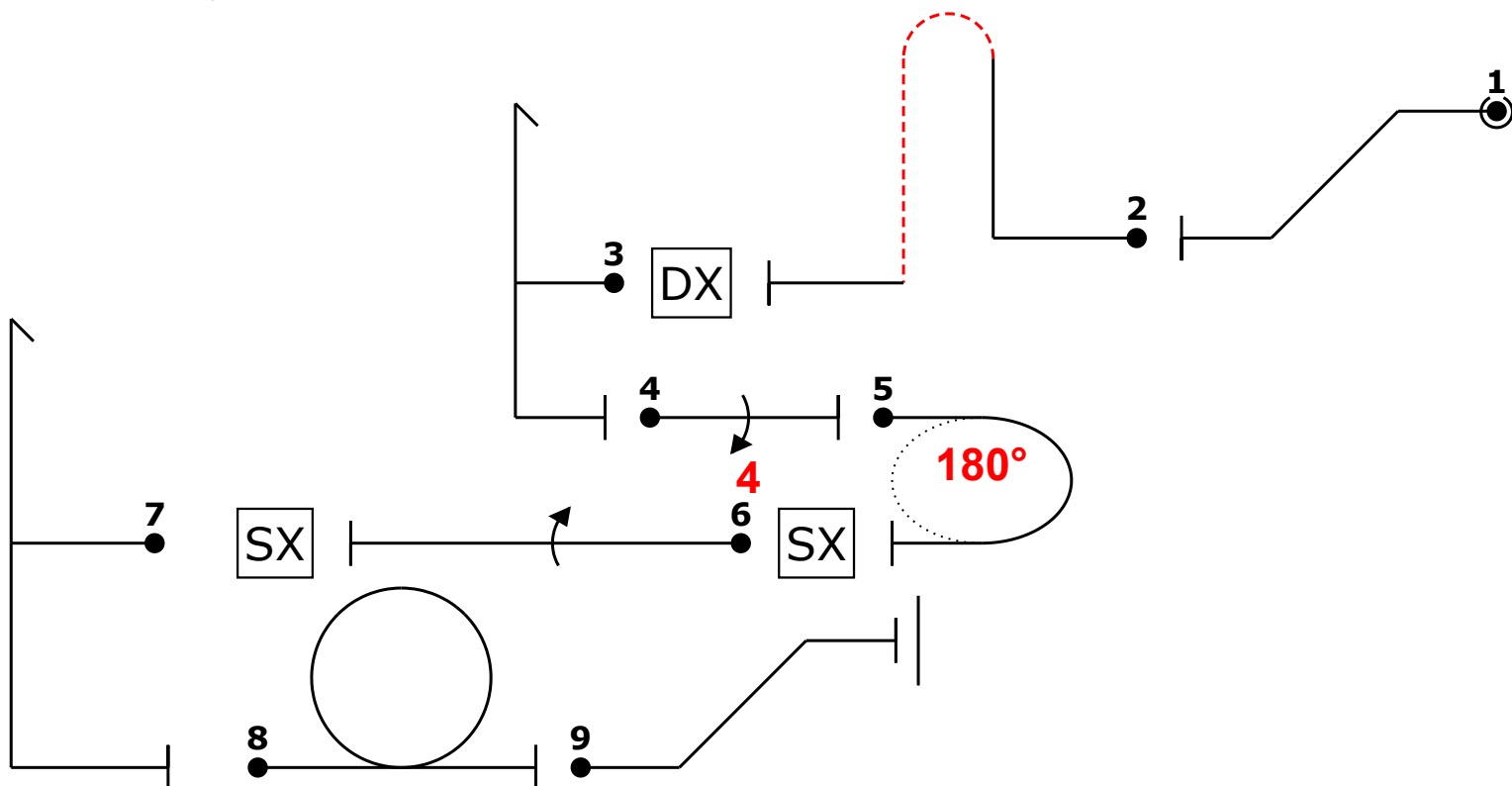
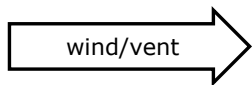

Check: 31-1-2020 8:40 OpenAero 2020.1 Sequence has errors:  
 No sequence validity checking rules active.  
 id pb "DX" h 44 2j "SX" . '1+~ "SX" 2> ~'h.' + 2> o d

\_\_\_\_\_  
 ..... Pilot  
**LIMITATO**  
 ..... A/C



**AERO CLUB D'ITALIA**

Form A	
Pilot ID	Flight #
<b>AeC Italia Glider INTERMEDIA Imposto Conosciuto</b>	

No	Symbol	Cat. No.	K	Total K	Grade	Pos	Remarks	Item	K	Grade								
1		<b>1.1.6.3</b> <b>9.11.1.6</b>	<b>10</b> <b>7</b>	17  SF 3	.			Pos.	10									
								Harm.	15									
2		<b>5.2.1.1</b>	<b>17</b>	17  SF 5	.			Fig K	Total K									
								134	159									
<b>Penalties</b>																		
3		<b>8.4.3.1</b>	<b>15</b>	15  SF 7	.			Too Low										
								Too High										
								Interruptions										
								Insertions										
								Trg Violation										
								Wing Rocks										
								Disqual Fig										
Other(note...)																		
4		<b>1.2.3.1</b> <b>9.1.2.2</b>	<b>12</b> <b>9</b>	21  SF 7	.			Trg Violation										
								Wing Rocks										
								Disqual Fig										
								Other(note...)										
								<b>Final Freestyle</b>										
																Duration	Min	Sec
5		<b>1.1.1.1</b> <b>9.4.3.4</b>	<b>2</b> <b>17</b>	19  SF 7	.			<b>Judges Details</b>										
								Signature										
								Name										
			Number															
6		<b>5.2.1.1</b>	<b>17</b>	17  SF 5	.			Signature										
								Name										
								Number										
7		<b>1.1.1.1</b> <b>9.1.3.4</b>	<b>2</b> <b>12</b>	14  SF 7	.			Signature										
								Name										
								Number										
8		<b>2.2.1.1</b>	<b>4</b>	4  SF 2	.			Signature										
								Name										
								Number										
9		<b>7.4.1.1</b>	<b>10</b>	10  SF 7	.			Signature										
								Name										
								Number										

ILLIMITATO  
 A/C  
 Pilot

		Form B
Pilot ID	AeC Italia Glider INTERMEDIA Imposto Conosciuto	Flight #

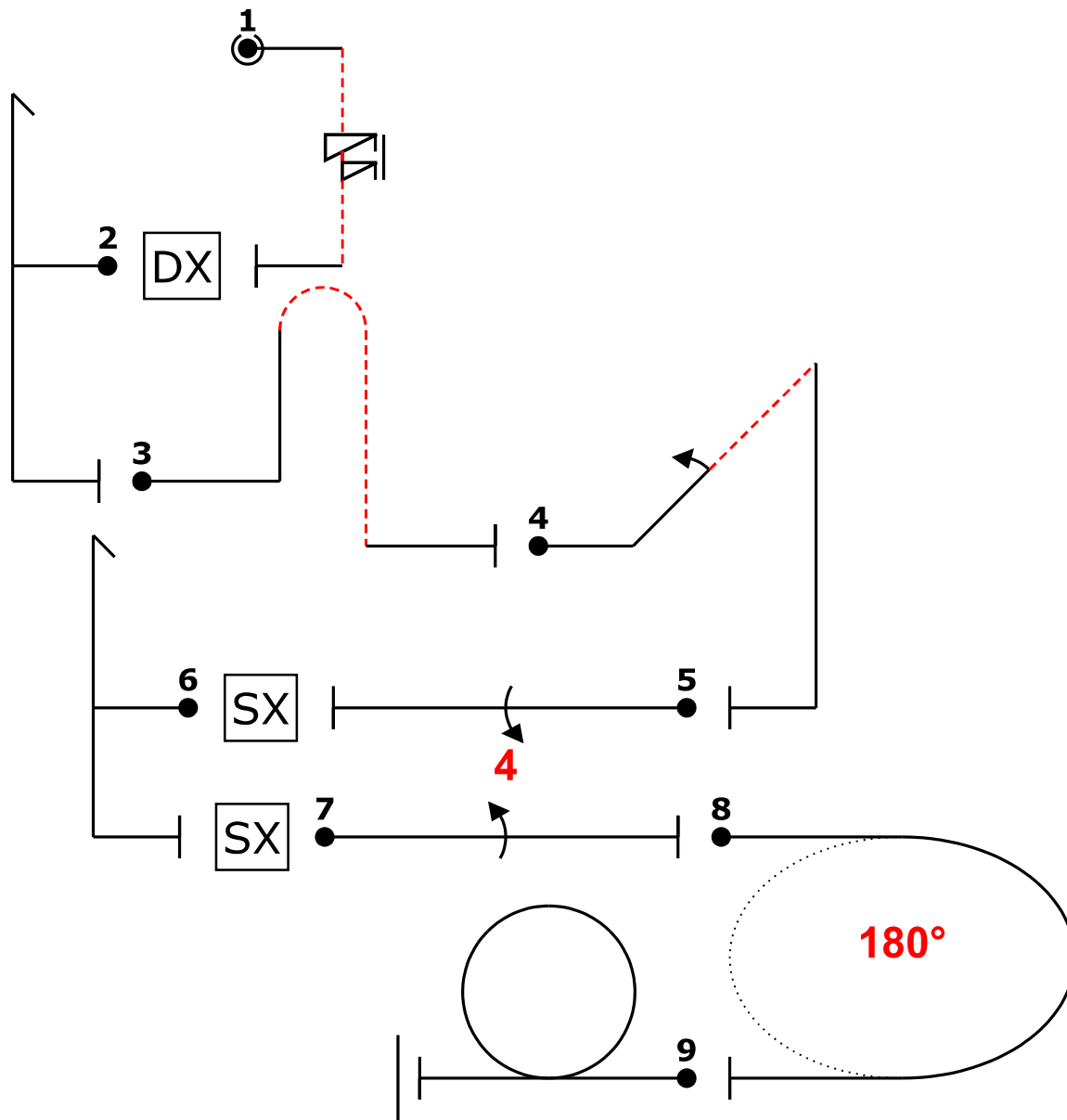
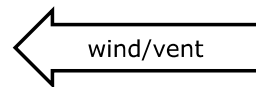

Glider			
Fig	Aresti	K	
1	1.1.6.3 9.11.1.6	10 7	17
2	5.2.1.1	17	17
3	8.4.3.1	15	15
4	1.2.3.1 9.1.2.2	12 9	21
5	1.1.1.1 9.4.3.4	2 17	19
6	5.2.1.1	17	17
7	1.1.1.1 9.1.3.4	2 12	14
8	2.2.1.1	4	4
9	7.4.1.1	10	10
<b>Total K = 134</b>			



AERO CLUB D'ITALIA

		Form C
Pilot ID	AeC Italia Glider INTERMEDIA Imposto Conosciuto	Flight #

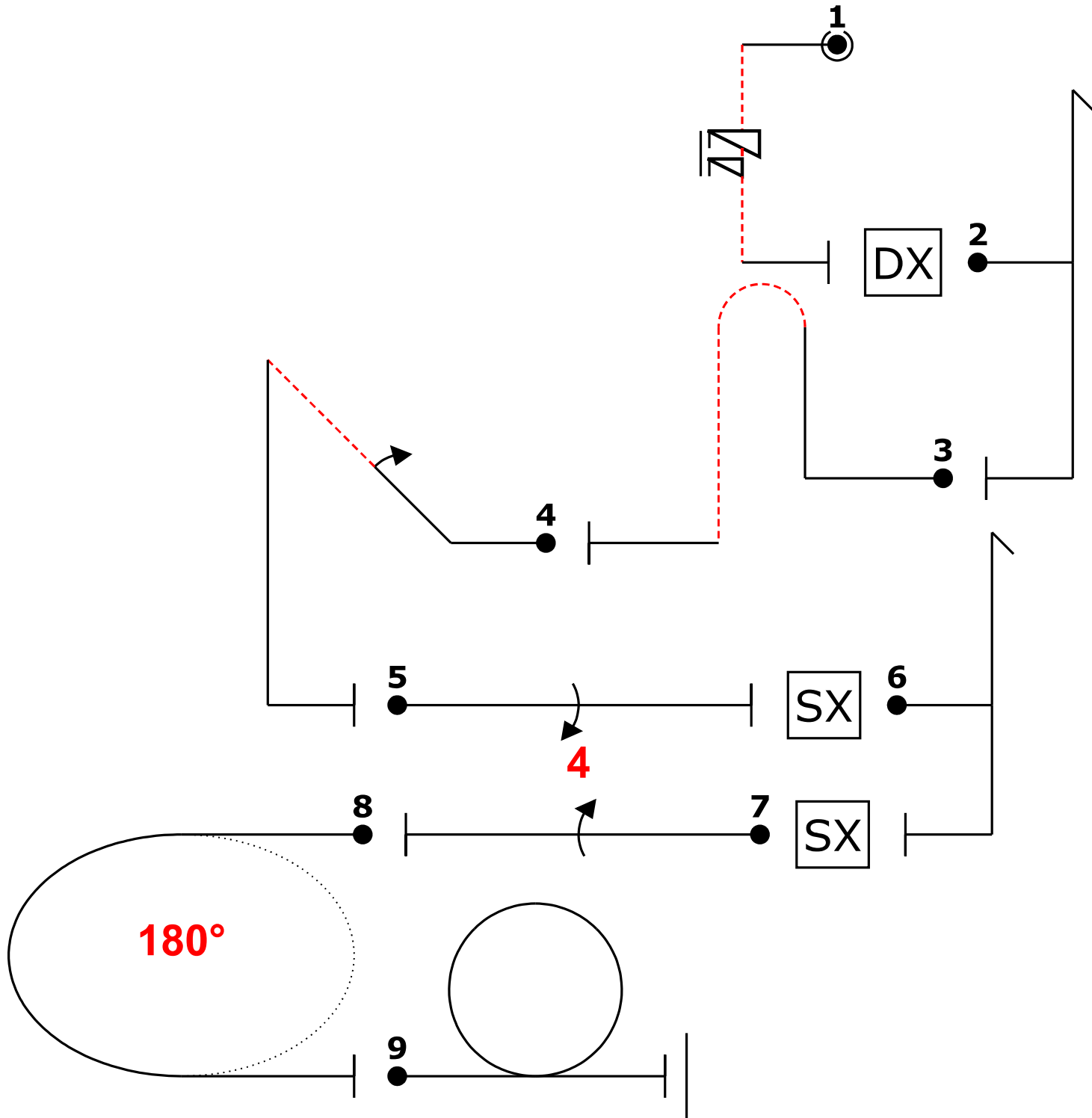
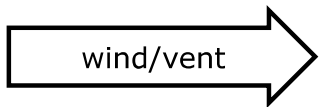

Check: 31-1-2020 15:44 OpenAero 2020.1 Sequence has errors:  
No sequence validity checking rules active.  
iv6s "DX" h.' `pb '2.t...' ~+44~ "SX" h "SX" ~+1+~ 10% 2j o

ILLIMITATO  
A/C  
Pilot